

FASTER TOAST FEWER SLOWDOWNS

Two belts + faster toast times + quick setting changes keep the line moving.



EFFICIENT INFRARED HEATING
Faster Toast - more uptime



HANDLES MENU FLEXIBILITY
Two bread types, side by side



CREW-FRIENDLY CONTROLS
Intuitive icons
32 tap-and-go presets



ENERGY-SAVINGS MODE
Up to 25% power reduction
during slow periods

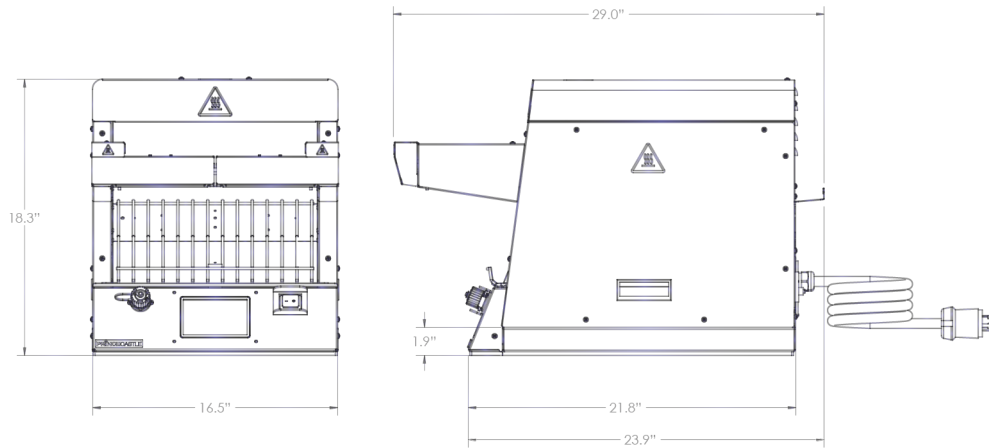

EASY TO SEE + REACH

Large control panel stays visible, even on a shelf

FITS TIGHT KITCHENS

16.5" on-counter width

MATCH HEAT TO THE BREAD

Top-only or Top + Bottom heaters

Technical Specifications

Product Category	Dual Lane IR Toaster
Packaging Dimensions	33.75"W x 21.0"D x 27.0"H
Shipping Weight	113 lbs
Power Requirements	208V, 60 Hz, 24A, Single Phase
Installation Type	Countertop
Toasting Type	Infrared Dual Belt
Operating Temperatures	700° - 900°F

Exterior Construction	Stainless steel construction with anti-slip rubber base
Bread Diameter	5.5" Single Lane / 11" dual lane
Belt	2x Wire belts with individually controlled toast time and temperature
Controls	5" LCD Touchscreen
Toasting Time	6-90 Seconds
Warranty	1 Year Parts and Labor

Model Numbers	Description	Heater Source	Volts	Hertz	Amps	Plug	Dimensions
IRTDLS2-GMS13	Infrared Toaster Dual Lane, Top Heaters	2x 2200W Upper Tubular IR heaters	208V	60Hz	24A	6-30P	16.5"W x 18.3"H x 21.8" D
IRTDLD2-GMS13	Infrared Toaster Dual Lane, Two Top and Two Bottom Heaters	2x 1500W Upper Tubular IR heaters 2x 980W Lower Tubular IR heaters	208V	60Hz	24A	6-30P	16.5"W x 18.3"H x 21.8" D
IRTDLS2-GMS22	Infrared Toaster Dual Lane, Top Heaters	2x 2200W Upper Tubular IR heaters	208V	60Hz	24A	L6-30P	16.5"W x 18.3"H x 21.8" D
IRTDLD2-GMS22	Infrared Toaster Dual Lane, Two Top and Two Bottom Heaters	2x 1500W Upper Tubular IR heaters 2x 980W Lower Tubular IR heaters	208V	60Hz	24A	L6-30P	16.5"W x 18.3"H x 21.8" D

Certifications



Contact your Prince Castle representative today to learn more about **Toast EZ**.