

High performing, heavy-duty slim-line toaster

297

Slim-Line Vertical Contact Toaster



Built for heavy-duty performance, the Slim Line 297 contact toaster from Prince Castle features a unique two-level platen that accommodates thicker bun-crowns and thinner bun-heels at the same time, ensuring perfect toasting. Its reliable motor and compact design make it a versatile and cost-effective choice.



Heavy-Duty Motor

Long-lasting performance in busy kitchens



Even Compression

Two-level platen evenly caramelizes up to 0.5" breads



Toasting Consistency

Heavy-duty platen retains heat, ensuring perfect toast all day



High Capacity

Up to 2,400 perfectly toasted buns per hour



Easy Maintenance

Simple to clean with minimal upkeep

Product Highlights

297

The 297 contact toaster offers exceptional capacity and consistency, making it the perfect choice for kitchens that demand durability and performance.



Low maintenance
Durable wire belt and long lasting components.

1



Easy to use
Simple controls and pre-set toast time.

2



User-friendly cleaning
Quick, easy daily upkeep for busy kitchens.

3

ELEVATE QUALITY AND REDUCE WASTE

- Heavy-duty, gear-driven motor ensures reliability and provides consistent output during peak hours.
- Advanced heating technology provides precision toasting and reduces waste, even during peak demand.
- Dual-level platen provides even compression for consistent toast quality for thick and thin breads.
- Adjustable compression settings minimize crushing of delicate buns and reduces waste.
- Self-adjusting belt assembly provides proper tensioning.
- Heavy-duty platen retains heat for perfect caramelization, even with continuous bun loading.
- Wire belt is low maintenance and long-lasting.
- Durable construction ensures consistent performance in demanding environments.

SIMPLIFIED OPERATIONS

- Individual models provide fixed toast times of 9, 12 and 20 seconds to provide consistent caramelization every time.
- Removable conveyor for easy maintenance.
- User-friendly design simplifies training for new staff.
- Toast up to 2,400 perfectly toasted buns per hour.

EASY TO CLEAN

- Stainless steel construction for quick and hassle-free cleaning.
- Non stick release sheets prevent residue build-up, ensuring lasting, optimal toaster performance.
- Easy access to key components ensures effortless upkeep.

SUSTAINABILITY

- Durable components reduce replacement needs.
- Minimal use of consumables supports eco-friendly operations.

SLIM-LINE DESIGN

- Fits easily into any kitchen workflow.
- Takes up less counter space.



Technical Specifications

297 Slim-Line Vertical Contact Toaster

Output & Electrical

Model N°	Description	Volts	Hz	Watts	Amps	Plug	Temperature range	Bread diameter	Variable speed	Pass through time	Belt
297-T9	Toaster, Slim line	115	60	1550	15.5	NEMA 5-15P	370-570°F 188-299°C	5.5" 14cm	No	9 sec	Wire
297-T9FCE	Toaster, Slim line, CE	230	50/60	1700	7.5	CEE 7.7	370-570°F 188-299°C	5.5" 14cm	No	9 sec	Wire
297-T9FGB	Toaster, Slim line, GB	230	50/60	1700	7.5	BS 1363	370-570°F 188-299°C	5.5" 14cm	No	9 sec	Wire
297-T12P	Toaster, Slim line	115	60	1550	15.5	NEMA 5-15P	370-570°F 188-299°C	5.5" 14cm	No	12 sec	Wire
297-T12PFCE	Toaster, Slim line, CE	230	50/60	1700	7.5	CEE 7.7	370-570°F 188-299°C	5.5" 14cm	No	12 sec	Wire
297-T20	Toaster, Slim line	115	60	1550	15.5	NEMA 5-15P	370-570°F 188-299°C	5.5" 14cm	No	20 sec	Wire
297-T20FCE	Toaster, Slim line, CE	230	50/60	1700	7.5	CEE 7.7	370-570°F 188-299°C	5.5" 14cm	No	20 sec	Wire
297-T20FGB	Toaster, Slim line, GB	230	50/60	1700	7.5	BS 1363	370-570°F 188-299°C	5.5" 14cm	No	20 sec	Wire

Product Dimensions + Weight

Width	25.0" (63,5cm)
Depth	8.2" (20.8cm)
Height	26.3" (66,8cm)
Unit Weight	71 lbs. (32kg)
Shipping Weight	82 lbs. (37kg)

Specifications

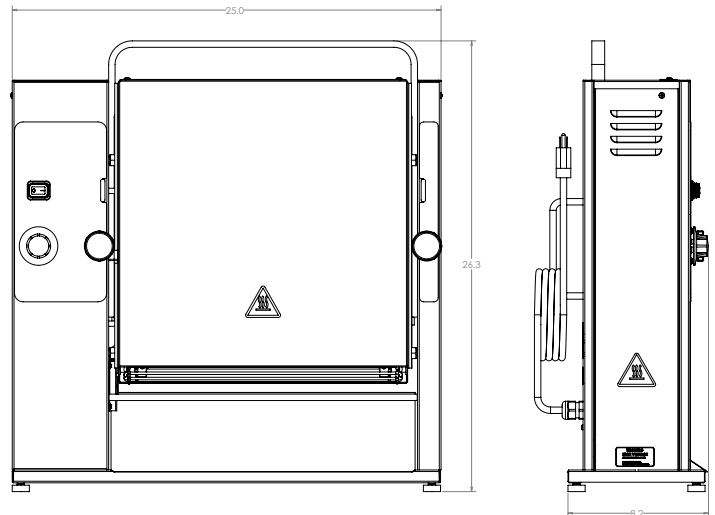

Accessories

Model Number	Description
511	Butter Wheel
197-260	Replacement 3 mil Release Sheets 2pk
196-12	Replacement 5 mil Release Sheets 2pk

Certifications



Replacement Release Sheets

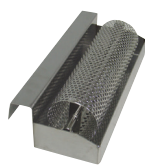

Butter Wheel

Whatever your needs, we've got the right solution for every toasting occasion.



Model	297-T9	297-T12P	297-T20	CTS	CTD	CTDE
Toaster Style	Contact, Continuous	Contact, Continuous	Contact, Continuous	Contact, Continuous	Contact, Continuous	Contact, Continuous
Unit Dimensions						
Width (in)	25.0"	25.0"	25.0"	20.3"	12.0"	17.5"
Depth (in)	8.2"	8.2"	8.2"	8.5"	10.8"	10.8"
Height (in)	26.3"	26.3"	26.3"	22.2"	21.3"	21.3"
Net Weight (lbs.)	71 lbs.	71 lbs.	71 lbs.	65 lbs.	51 lbs.	70 lbs.
Shipping Dimensions						
Width (in)	26.0"	26.0"	26.0"	24.5"	16.5"	21.8"
Depth (in)	12.2"	12.2"	12.2"	13.0"	16.3"	15.8"
Height (in)	27.6"	27.6"	27.6"	27.0"	28.3"	21.1"
Shipping Weight (lbs.)	82 lbs.	82 lbs.	82 lbs.	68 lbs.	56 lbs.	75 lbs.
Bun Specifications						
Bread Diameter (in)	5.5"	5.5"	5.5"	5.5"	5.5"	5.5"
Crown Min (in)	0.75"	0.75"	0.75"	0.5"	0.4"	0.4"
Crown Max (in)	1.25"	1.25"	1.25"	1.25"	1.25"	1.25"
Heel Min (in)	0.5"	0.5"	0.5"	0.3"	0.3"	0.3"
Heel Max (in)	1.0"	1.0"	1.0"	1.0"	1.0"	1.0"
Buns per Hour	2,400/hr	2,400/hr	2,400/hr	1,200/hr	1,200/hr	2,400/hr
Product Specifications						
Platen	Single Sided	Single Sided	Single Sided	Single Sided	Dual Sided	Dual Sided
Belt	Wire	Wire	Wire	Wire, Silicone	Silicone	Wire, Silicone, Stainless steel
Variable Speed	No	No	No	Yes	Yes	Yes
Temp Range	370-570°F	370-570°F	370-570°F	100-550°F	100-550°F	100-550°F
Pass Through Time	9 sec	12 sec	20 sec	9-40 sec	6-40 sec	6-40 sec
Volts	115V	115V	115V	115V	208-240V	208-240V
Hertz	60 Hz	60 Hz	60 Hz	60 Hz	60 Hz	60 Hz
Watts	1550W	1550W	1550W	1550W	1700-2250W	2440-3250W
Amps	15.5	15.5	15.5	15.5	8.1-9.4	11.7-13.5
Plug	NEMA 5-15P	NEMA 5-15P	NEMA 5-15P	NEMA 5-15P	NEMA L6-20P	NEMA L6-20P
Warranty	1-Year Parts & Labor	1-Year Parts & Labor	1-Year Parts & Labor	1-Year Parts & Labor	1-Year Parts & Labor	1-Year Parts & Labor
Accessories	Butter Wheel, Release Sheet Kit	Butter Wheel, Release Sheet Kit	Butter Wheel, Release Sheet Kit	Butter Wheel, Release Sheet Kit Silicone Belt	Butter Wheel, Release Sheet Kit Silicone Belt	Butter Wheel (Wire/Silicone only), Release Sheet Kit; Silicone Belt
Agency Listings	UL Safety, UL Sanitation, CE, EAC, UKCA	UL Safety, UL Sanitation, CE, EAC	UL Safety, UL Sanitation, CE, EAC	UL Safety, UL Sanitation, CE, EAC, UKCA	ELT Safety, ELT Sanitation, CE, EAC, UKCA	ELT Safety, ELT Sanitation, CE, EAC, UKCA

PRINCECASTLE

The perfect toast, every time.



To learn more about Prince Castle toasters, visit princecastle.com
To contact a Prince Castle representative, go to princecastle.com/contact/

355 E. Kehoe Blvd.
Carol Stream, IL 60188
1.800.PCASTLE • 1.800.722.7853 - 630.462.8800



Marmon Foodservice
Technologies

A Berkshire Hathaway Company