

# OPERATION MANUAL

## PHB33 Holding Bin



**TABLE OF CONTENTS**

PRODUCT REGISTRATION .....2

SAFETY INFORMATION .....3

SPECIFICATIONS .....4

UNBOXING & INSTALLATION .....5

DEFAULTS MENUS.....6

OPERATION .....7

VIEWING AND ADJUSTING SETTINGS .....8

MANAGER ADVANCED PROGRAMMING .....10

SOFTWARE UPDATE.....17

HEATER CALIBRATION.....18

CLEANING .....20

EXPLODED PARTS VIEW .....21

PARTS LIST.....22

TROUBLESHOOTING .....23

WIRING DIAGRAM .....24

**LIMITED WARRANTY**

This product is warranted to be free from defects in material and/or workmanship for a period of 2 years from date of original installation, not to exceed 30 months from the date of manufacture.

Any component which proves to be faulty in material and/or workmanship will be replaced or repaired (at the option of Prince Castle, LLC) without cost to the customer for parts and labor. This warranty covers on location service (i.e. trip charges and or mileage). Travel mileage is limited to 100 miles (200 kilometers) round trip (one trip warranty) from an authorized service agency or its sub-service agency.

This warranty is subject to the following exceptions/ conditions:

Use of any non-genuine Prince Castle parts voids this warranty.

All labor to be performed during regular work hours. Over- time premium (the incremental amount) will be charged to the customer.

Damage caused by carelessness, neglect and/or abuse (e.g., dropping, tampering or altering parts, equipment damaged in shipment, by fire, flood or an act of God) is not covered under this warranty.

All problems due to operation at voltages other than that specified on equipment nameplates are not covered by this warranty. Conversion to correct voltage is the customer's responsibility.

This equipment must be serviced by Prince Castle Authorized Service Agency or a Prince Castle Service Technician during the warranty period.

**Prince Castle, a Marmon Foodservice Technologies brand**  
**355 East Kehoe Blvd, Carol Stream, IL 60188**  
**1-800-PCASTLE | info@princecastle.com | princecastle.com**

# EQUIPMENT REGISTRATION



Thank you for purchasing equipment from the Marmon Foodservice Technologies family of brands. Registering your purchase will help us keep you up-to-date with preventative maintenance resources and other relevant information regarding your machine(s). Marmon Link is the dedicated provider of the industry's most comprehensive after-sales support for Cornelius, Prince Castle, Silver King, and Angelo Po products. From technical questions to warranty service dispatch, replacement parts and more, our goal is to ensure your equipment functions as intended.

To complete this process, you will need:

- The serial number of the equipment
- The name and email address for a designated store contact
- General store information, including location number or address

## REGISTER YOUR EQUIPMENT

**To Maximize Your Benefits**

- \* Comprehensive after-sales service
- \* Over the phone technicians
- \* Quick-ship parts

**Complete with:**

- \* Serial Number
- \* Equipment location details



Scan the QR Code

Your equipment serial number will be validated against our database of existing serial numbers. If you are having difficulties entering a valid number, please contact MarmonLink Customer Care team @ **1-866-275-6392**

# SAFETY INFORMATION

 **WARNING**

These appliances are meant for commercial use, such as in restaurant kitchens, canteens, hospitals, and various commercial enterprises like bakeries and butcheries. However, they are not intended for continuous mass food production. Do not clean the appliance with a water jet or steam cleaner. Keep the unit away from running water. Always adhere to instructions provided for cleaning and maintenance procedures.

The appliance is not intended for use by persons (including children) with reduced physical, sensory or mental capabilities, or lack of experience and knowledge, unless they have been given supervision or instruction concerning use of the appliance by a person responsible for their safety. Children shall not be allowed to use or play with this appliance.

 **WARNING**

Indicates information important to the proper operation of the unit. Failure to observe may result in damage to the equipment and/or severe bodily injury or death.

 **CAUTION**

Indicates information important to the operation of the unit. Failure to observe may result in damage to the equipment.

# SPECIFICATIONS

Model	Width	Height	Depth	Weight	Voltage / Ph /	Power	Plug Style
PHB33N1-WEN02	23.00" (58.4cm)	22.61" (57.4cm)	14.00" (35.6cm)	65 Lbs.	120V / 1 / 60	1920 Watts	5-20P

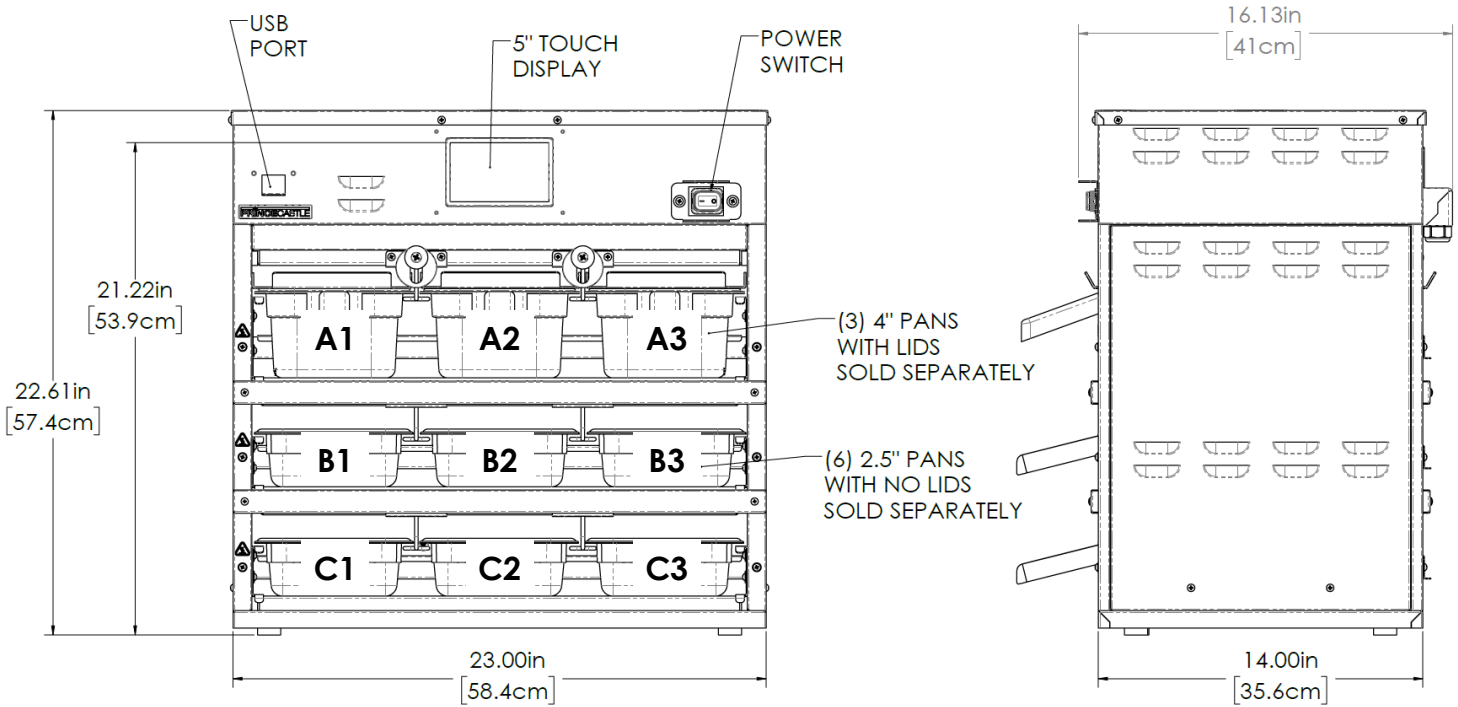

Prince Castle reserves the right to change specifications and product design without notice. Such revisions do not entitle the buyer to corresponding changes, improvements, additions or replacements for previously purchased equipment.

# UNBOXING

Remove the unit from the carton and inspect for signs of damage. If there is damage to the unit:

- Notify the carrier within 24 hours of delivery,
- Save carton and packaging materials for inspection purposes,
- Contact your local dealer, or if purchased directly, contact MarmonLink Customer Care team @ **1-866-275-6392**

# INSTALLATION

**⚠ CAUTION**

All electrical connections must be in accordance with local electrical codes and any other applicable codes.

**⚠ WARNING**

Disconnect all power before attempting installation

**LOCATION**

When installing this unit, the ambient temperature at the mounting site should not exceed 100°F (38°C)

The unit must be sealed to the counter. Apply a continuous bead of NSF International (NSF) silicone sealant (Dow 732 or equal) approximately 1/4-inch around the outside of the unit. All excess sealant must be wiped away immediately.

**ELECTRICAL**

Product requires a dedicated 120V 1-Phase 20A capacity grounded receptacle with matching plug configuration.

**MINIMUM UNIT CLEARANCES**

Front	Sides	Rear	Top
24" (61cm)	0" (0cm)	1.5" (3.8cm)	Open

**STACKING**

Holding Bin is not load-bearing. Do not place another unit or other weight on top of the unit

**PASS-THRU OPTION**

Unit is designed to convert as a Pass-thru unit. See Parts List on page 20 for pan, trivet and lid part numbers.

- Loosen screws holding pan stop brackets
- Lift bracket up to remove
- Retighten screws

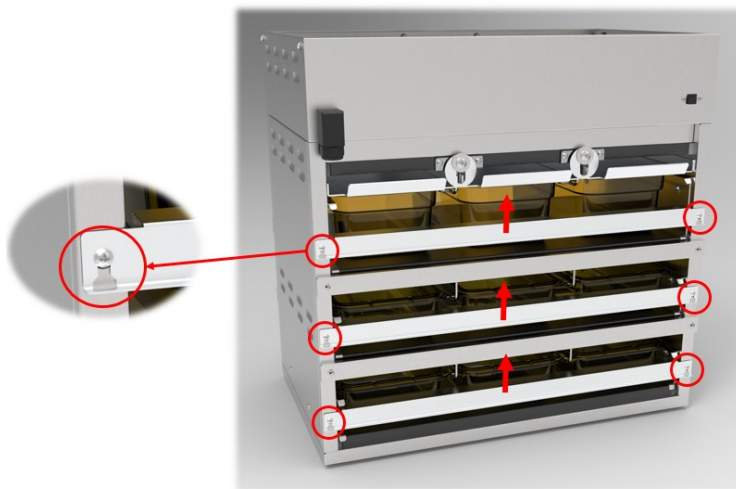

# DEFAULT MENUS

**NOTE: Unit is pre-programmed from the factory per the below information**

Description	Display Name	Lower Hold Set Point °F	Lower Hold Set Point °C	Upper Hold Set Point °F	Upper Hold Set Point °C	Hold Time (minutes)	Cook More Time (minutes)	Daypart
Eggs	EGG	190	88	190	88	60	5	1
Sausage	SAUS	190	88	190	88	120	6	1
Breakfast Chicken	BFST	190	88	190	88	30	5	1
Cinnabon	CINN	190	88	190	88	15	NA	1
Breakfast Burrito	BURR	190	88	190	88	90	5	1
Classic Chicken	CLSC	190	88	190	88	30	6	2
Spicy Chicken	SPCY	190	88	190	88	30	6	2
Crispy Chicken	CRSP	190	88	190	88	30	5	2
Diced Chicken	DICE	190	88	190	88	30	5	2
Baked Potato	POT	190	88	190	88	120	NA	2

Daypart 1 (AM)		
Eggs	Eggs	Cinnabon
Sausage	Breakfast Chicken	Burrito
Sausage	Breakfast Chicken	Burrito

Daypart 2 (PM)		
Diced Chicken	Diced Chicken	Potato
Spicy Chicken	Classic Chicken	Crispy Chicken
Spicy Chicken	Classic Chicken	Crispy Chicken

# OPERATION

**1 Turn unit on.** Turn the On/Off switch, located on the front right corner of the unit.

The Prince Castle logo and version information will appear in the display.



**2 Wait through warm-up.** On the Warm-Up screen, the thermometer icon will be flashing.

*NOTE: During use, any time the set point is changed from its previous setting, the Warm-Up screen will display until the set point is reached.*



Warming Up...

When the set points for all bins are reached, the Home screen appears and the **DAYPART ICON** will appear on top left corner of the screen.

**Daypart Icon**

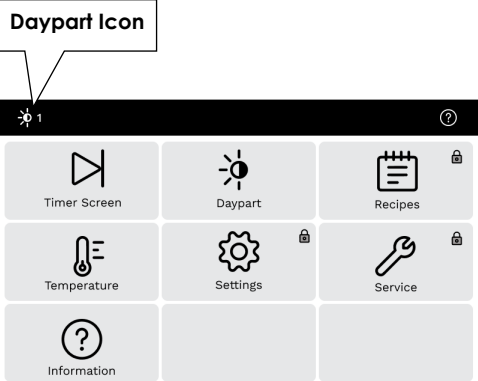

**3 View the daypart setting.** The daypart is shown at the top left corner of the screen, and its small number is the current daypart setting. 1 = Breakfast 2 = Non-Breakfast Items

**Daypart Icon**

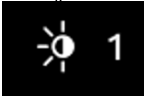

**4 Make any desired adjustments.** Use the instructions in *Viewing and Adjusting Settings* to switch dayparts.

**5 Select Timer Screen**

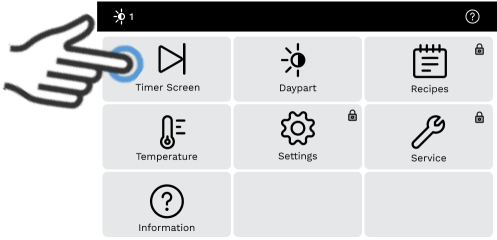

**6 Load each bin as needed and touch the product icon to start its timer.** While running, the Timer screen will toggle between the product name (EGG, CINN ...) and the actual time remaining for each bin.

*NOTE: To cancel the timer while running, see step 7.*



**7 Product FIFO System**—The unit utilizes a FIFO (First In, First Out) system to indicate to the user which pan to pull product from first when multiple pans of the same product are being held.

**Green (steady) = oldest product, use first**  
**Yellow (steady) = newer product, use Green first**  
**Red (steady) = new / ready product**

**8 You may cancel the timer while running.** From the Timer screen, tap the product name **THREE** times for the bin you wish to stop. Select End/Trash Icon to cancel timer OR back icon to return to previous screen.

*NOTE: cancel function will time out after 3 seconds if nothing is selected and return to timer in progress*

**Timer Ended—Discard product**      **Product Name**

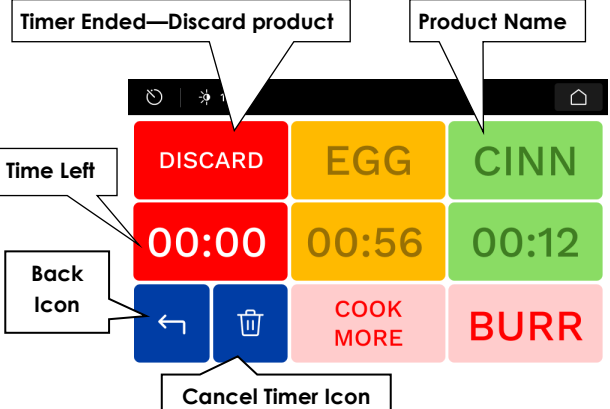

**Time Left**

**Back Icon**

**Cancel Timer Icon**

**9 You may restart the timer after countdown ends.** At the end of a timer countdown, the delete icon will begin to flash for that bin. Touch the icon once to cancel the alert.

# VIEWING AND ADJUSTING SETTINGS

**1 View the Main Menu screen.** From the Timer screen, touch the HOME icon

**The Main Menu screen will appear.**

*NOTE: From the Main Menu screen, touch the TIMER SCREEN icon on the upper left corner to return to the Timer screen at any time.*

**2 Change the daypart that is running.**

Touch the Daypart icon on the Home screen. The Daypart Selection screen will appear with the current daypart setting highlighted.

**3 Using the ARROW icons,** touch and scroll to desired daypart. Touch CONFIRM icon to accept OR BACK icon to go back to previous screen. There are TWO dayparts that can be selected.

1 = Breakfast items  
2 = Non-Breakfast items  
3 thru 6 are not pre-programmed but can be by end user if needed.

**4 Make any desired adjustments.** Use the instructions in *Manger Advanced Programming* to make changes to daypart and/or bin temperature settings.

# VIEWING AND ADJUSTING SETTINGS

**5 View Temperature settings** Touch the Temperature icon on the Home screen. The Daypart Selection screen will appear with the current daypart setting highlighted.  
*Note: this is for viewing reference only. See Advanced Manger Programming to modify recipe temperatures.*

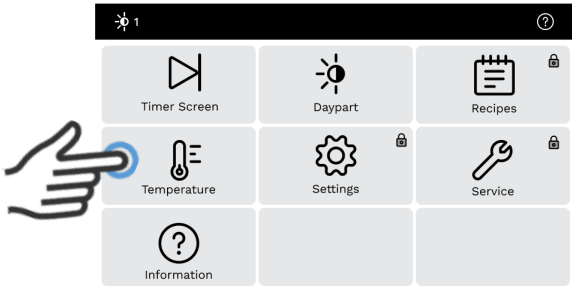

**6 There are two icons**, one for Setpoint temperature and the another for actual heater temperatures. Use the scroll icons to review temperatures on each zone. Select the Home icon to return to the previous screen.

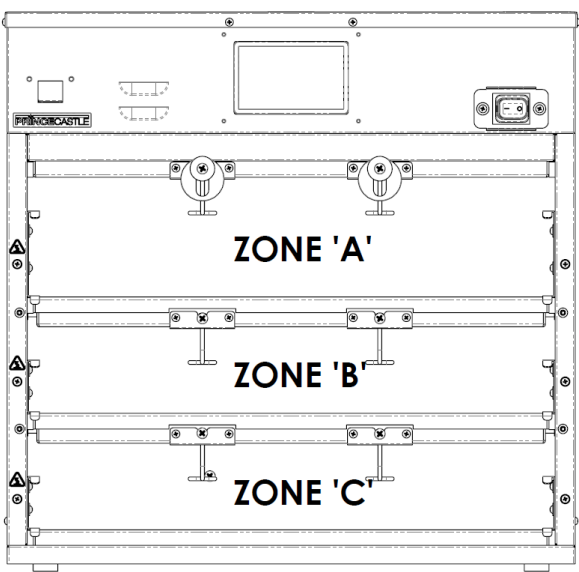
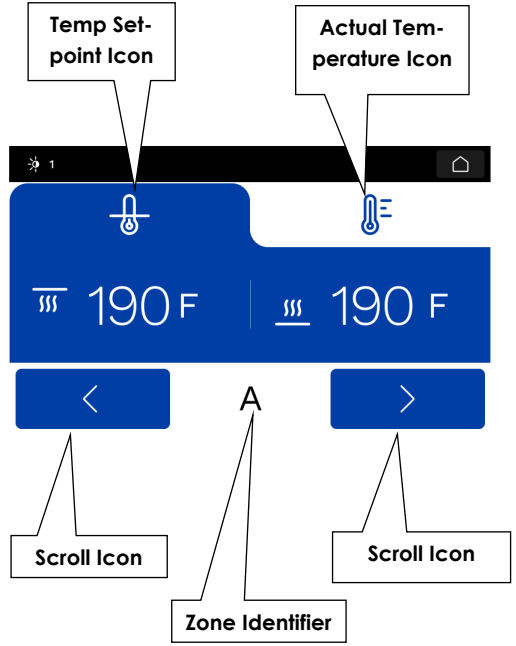

# MANAGER ADVANCED PROGRAMMING

## 1 Change / Modify Dayparts

Touch the Daypart icon on the Home screen. The Daypart Selection screen will appear with the current daypart setting highlighted.

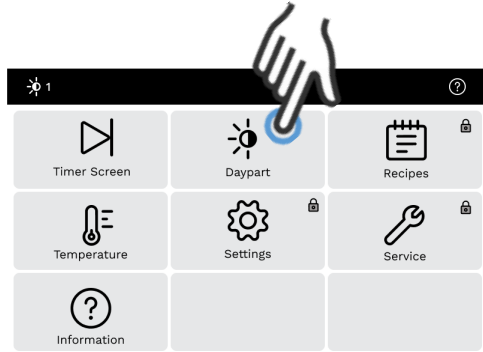

## 2 Using the ARROW icons, touch and scroll to desired daypart number. Touch the number in middle of the screen.

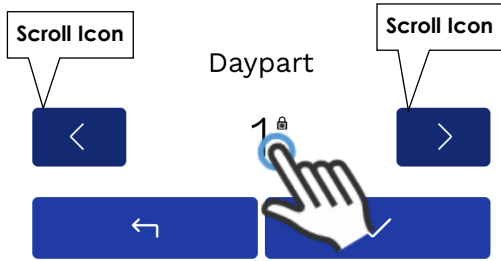

## 3 In the Daypart editor, a user can select one or multiple locations to assign at once. Selected recipes will turn from blue to white

*Note: Column 1 contains the controlling temperature for each row. Recipes in columns 2 or 3 will be replaced by the assignment in column 1. Only recipes that share the **same temperature profiles** can be included in a row.*

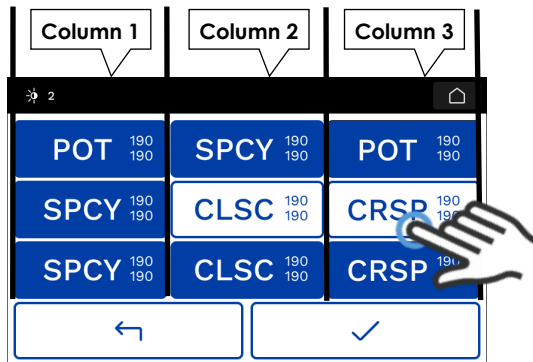

## 4 Using the ARROW icons, touch and scroll to desired recipe. Select Confirm to use OR Back to return to previous screen

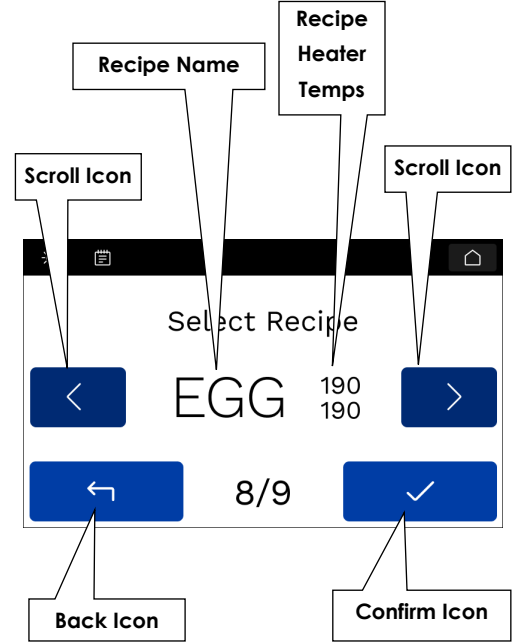

## 5 At this stage, you can either keep modifying the daypart menu layout by repeating steps 4 and 5, or confirm your selections by clicking the Confirm icon. Alternatively, you can choose the Back icon to cancel and go back to the Home screen.

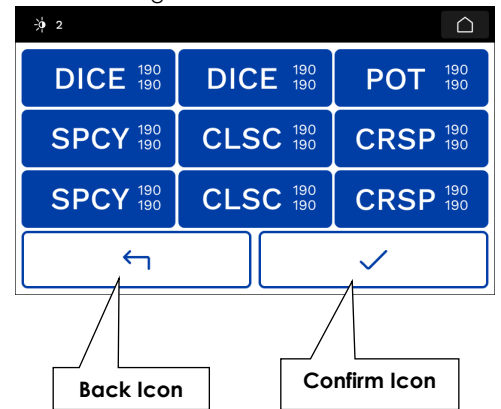

# MANAGER ADVANCED PROGRAMMING

**1 Change / Modify Recipes**  
Touch the Recipes icon on the Home screen.

**2 Enter PIN**  
*NOTE: Default PIN is 1234 and cannot be changed at this time*

**3 At this point, you can select to change a recipe temperature, hold time and name.**

**4 To modify Recipe name, select Edit Name icon. This will bring you to the character entry keyboard**

**5 At this point, you can modify name using the character keyboard. Select the Confirm icon to accept changes or Back icon to return to previous screen**

**6 To modify Recipe temperature, select Edit Temperature icon. This will bring you to the character entry keyboard**

# MANAGER ADVANCED PROGRAMMING

**7** There are two icons, one for top and another for bottom heater. Use the minus and plus icons to modify temperatures OR tap on the temperature and it brings you to the number keypad where desired value can be entered. Select the Confirm icon to accept changes or Back icon to return to previous screen

**8** To modify Recipe holding time, select Edit Time icon. This will bring you to the character entry keyboard

**9** There are two icons, one for Hold Time and another for Cook More. Use the minus and plus icons to modify temperatures OR tap on the time and it brings you to the number keypad where desired value can be entered. Select the Confirm icon to accept changes or Back icon to return to previous screen

# MANAGER ADVANCED PROGRAMMING

**10** To view errors and notifications, a yellow error icon (yellow triangle) appears in the upper right corner of the screen. Touch the ERROR icon to display the error and description of the error. Refer to the troubleshooting section for more error details.  
Use the ARROW icons to scroll thru additional errors.

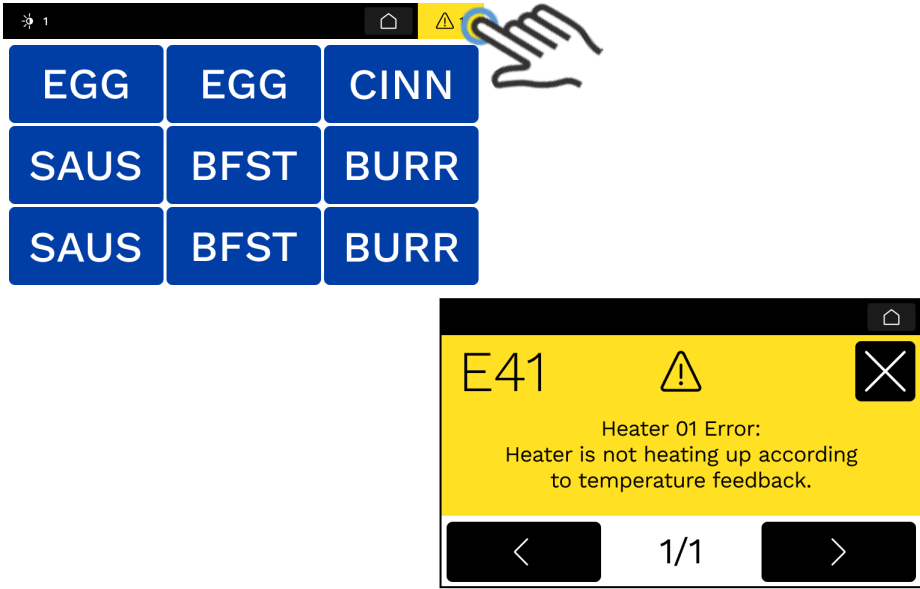

**11** To access error logs and statistics, touch the SERVICE icon on the Home screen. Input your PIN and the Service screen will appear.  
*NOTE: Default PIN is 1234 and cannot be changed at this time*

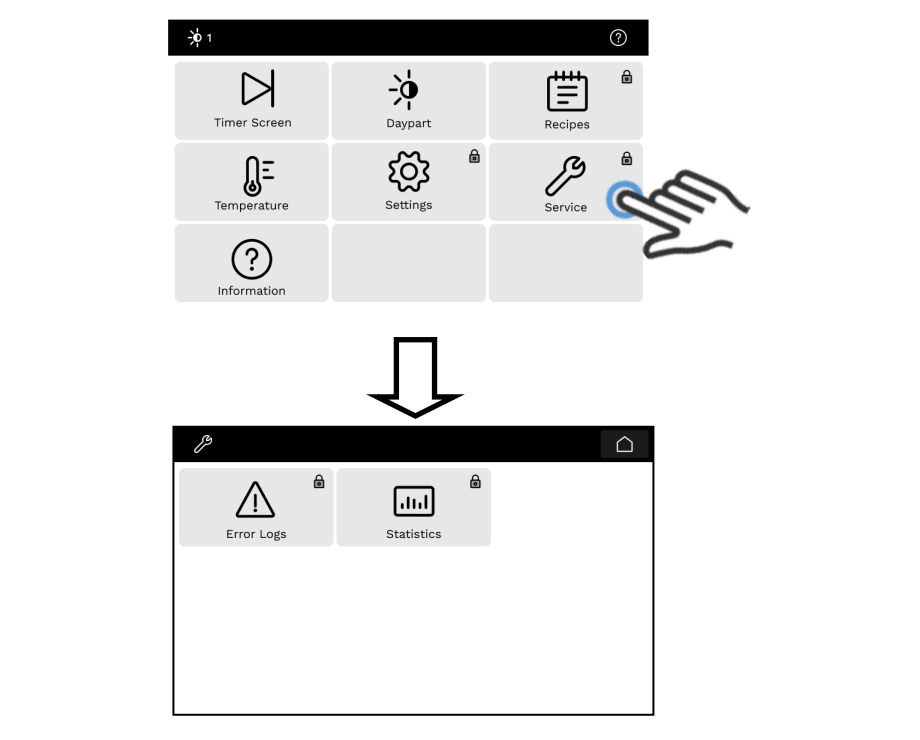

# MANAGER ADVANCED PROGRAMMING

**12** Touch the error logs icon. The Error Log screen will appear.

The Error Log screen shows a list of errors with a timestamp. Select from the list for details.

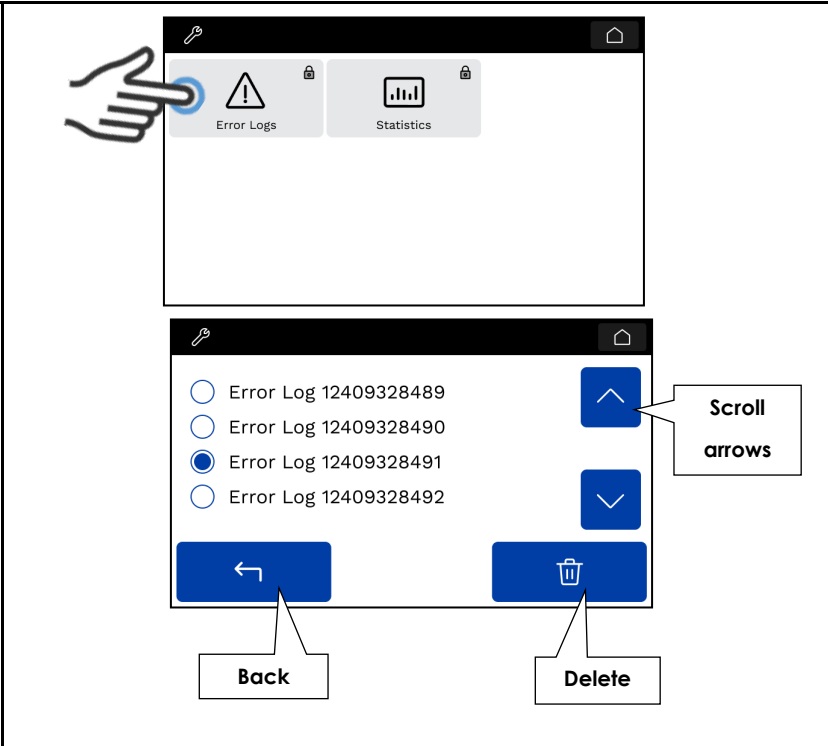

**13** Touch the statistics icon, the Statistics screen will appear.

The only statistic is Run Time

Touch the BACK icon to return to the previous screen.

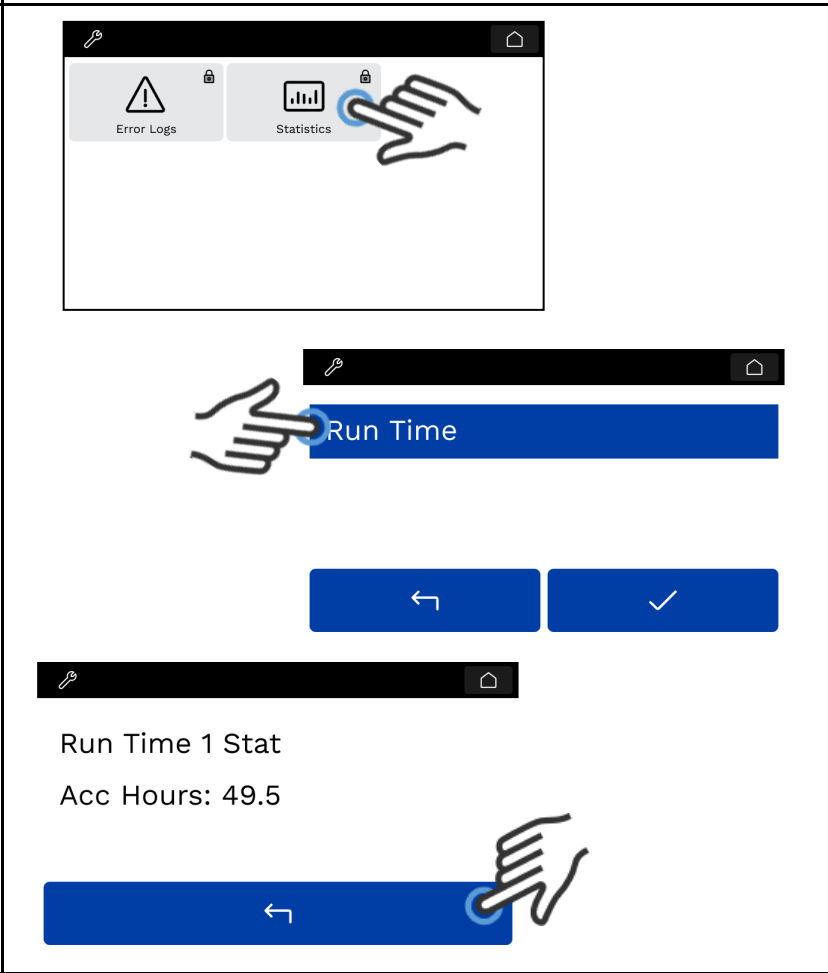

# MANAGER ADVANCED PROGRAMMING

**14** Change settings for Language, Screen Brightness, Temperature Units and Sound Level. From the Home screen, you can access and change various unit settings under the SETTINGS icon.

*NOTE: Grayed out icons are not available at this time*

Enter PIN

*NOTE: Default PIN is 1234 and cannot be changed at this time*

Touch LANGUAGE icon to change displayed language. Select your language (default is ENGLISH) and touch CONFIRM icon to accept or BACK icon to go back

Touch SCREEN BRIGHTNESS icon to change display brightness. Use the + and - icons to increase / decrease. Touch CONFIRM icon to accept or BACK icon to go back

Touch TEMPERATURE UNITS icon to change displayed temperature format. Select Fahrenheit (Default) or Celsius. Touch CONFIRM icon to accept or BACK icon to go back

Touch VOLUME icon to change S sound level. Use the + and - icons to increase / decrease. Touch CONFIRM icon to accept or BACK icon to go back

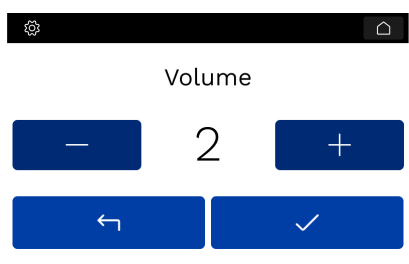
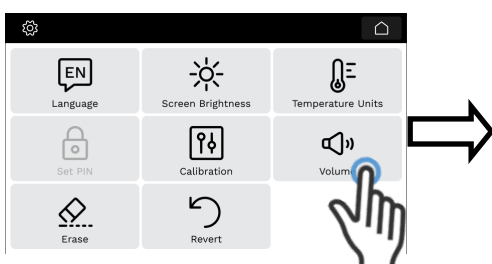
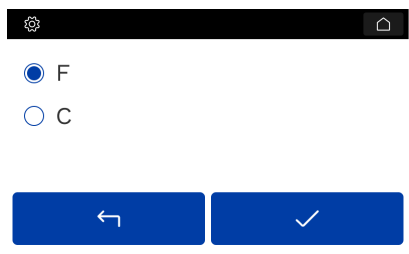
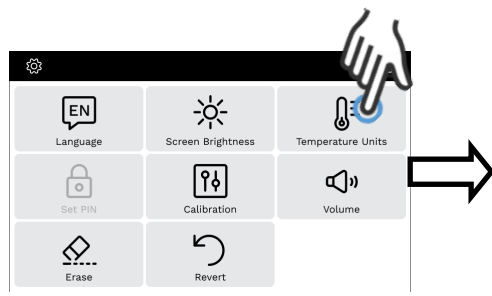
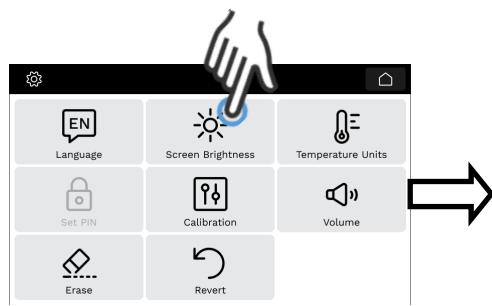
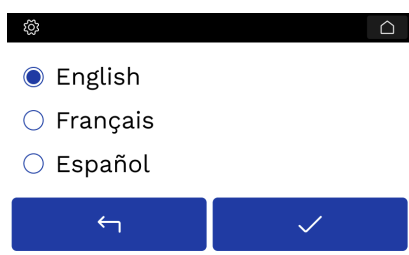
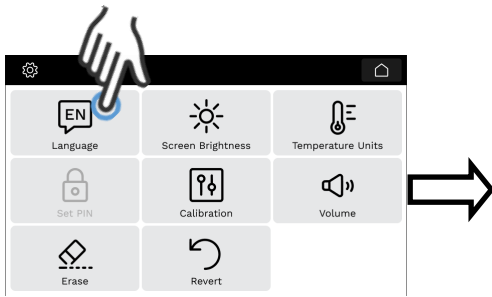
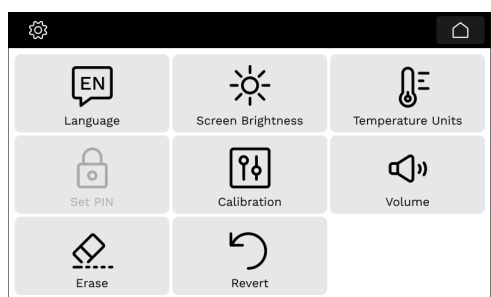

# MANAGER ADVANCED PROGRAMMING

**15** Also under the SETTINGS icon, there is an ERASE icon

There are three options to erase  
**External Flash**  
**Error Log** (all error logs)  
**EEPROM** (custom settings / changes. This does not erase software)

Touch the CONFIRM icon to accept or BACK icon to cancel

Final confirmation will be shown. Touch the CONFIRM icon to proceed or BACK icon to cancel

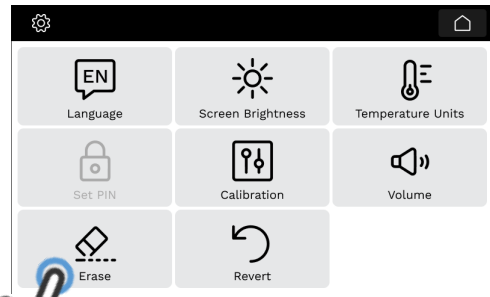

External Flash  
 Error Log  
 EEPROM

Back Confirm

EEPROM will be reset

Back Confirm

**16** Lastly under the SETTINGS icons is REVERT. This option undoes last version download of the unit software to the previous version

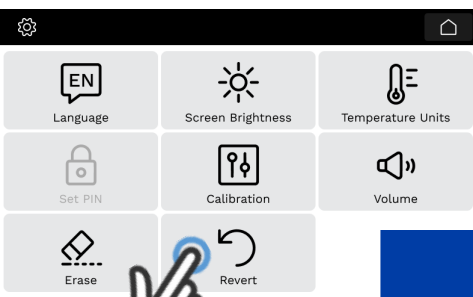

Undo last file download?

Back Confirm

# SOFTWARE UPDATES

**1 Update the system with a USB stick.** With a USB stick, you can update the unit's software.  
 Turn OFF unit and insert a USB stick containing the correct software.  
**Please note that only the new software file(s) should be on the USB drive, nothing else. DO NOT CREATE A FOLDER to place files into.**  
**USB stick should be 4GB or less**

The system will enter reprogramming mode and a symbol will flash during reprogramming. When complete, unit will return to normal operation.

**2** Turn ON unit...system will upgrade the software automatically. Once updated, unit will reboot and you should notice the new software version under the Prince Castle logo. Unit will be completed updated when the HOME screen

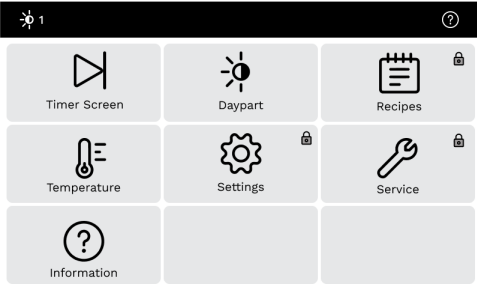

➔

**3** Go to the SETTINGS screen, there is an ERASE icon

Select the EEPROM icon

Touch the CONFIRM icon to accept or BACK icon to cancel

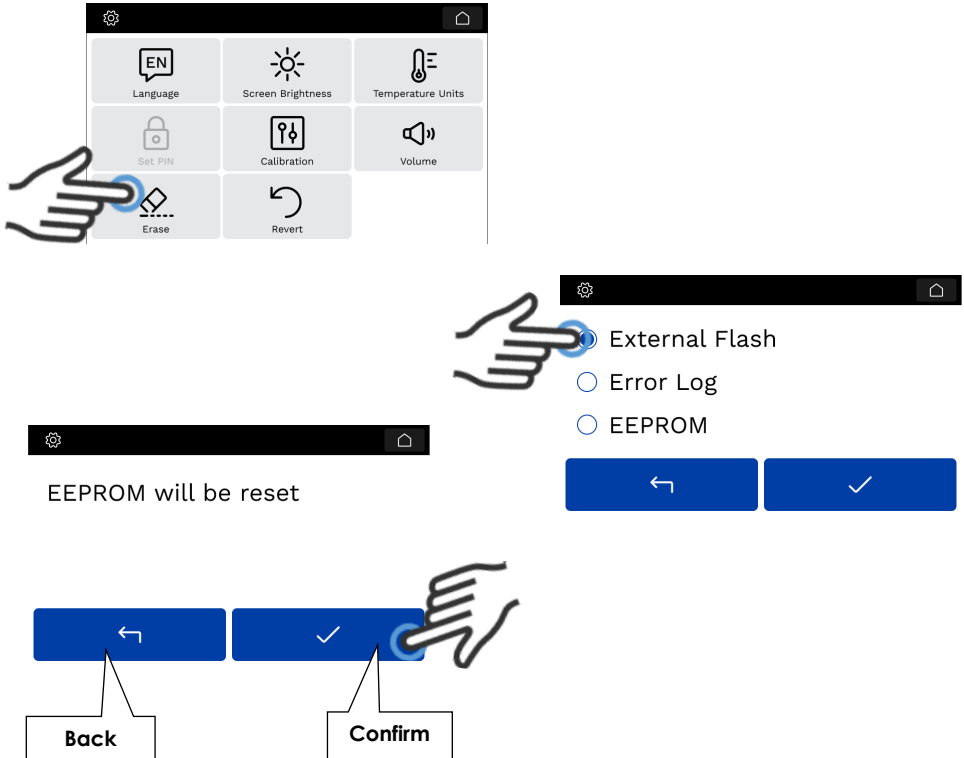
Final confirmation will be shown. Touch the CONFIRM icon to proceed or BACK icon to cancel



Back

Confirm

# HEATER CALIBRATION

Heater calibration should only be done if the actual heater temperatures are +/-10F (5.6C) from set point temperature OR if a PCB has been replaced. Units are checked and calibrated from the factory. Unit location / environment (i.e...by drive-thru window, under A/C return vent, etc.) may play a role in heater settings.



## WARNING

Heater calibration must be performed while the unit is ON. Be sure to use protective gloves to prevent bodily injury.

### Tools Needed

Calibrated K-Style Thermocouple Surface Probe



Heat Resistant Gloves



1

**NOTE: Make sure all heater shelves are clean and oil / grease / debris free**

Be sure unit is ON and reached set point temperatures before proceeding

Touch the CALIBRATION icon. The Calibration screen will appear.

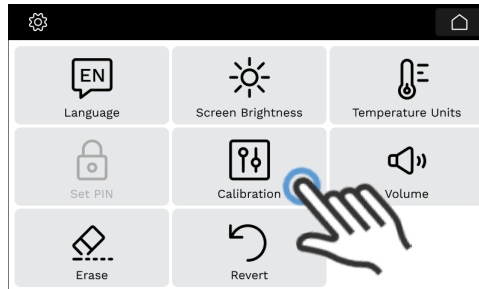

2

**NOTE: Make sure temperature probe surface is clean and oil / grease / debris free**

With the probe, measure temperature at the center of the heater plate you want to adjust.

Record temperature reading

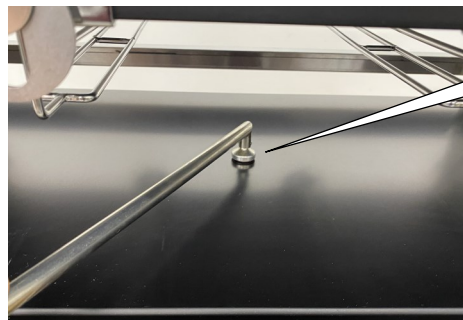

Center of heater plate

3

Using the SCROLL icons, go the zone you want to change

Make sure you're on the right heater, upper or lower, you want to change.

Using the + - icons OR touch and hold the current value to call up the Value Input screen. Change the displayed temperature to the recorded temperature in step 2.

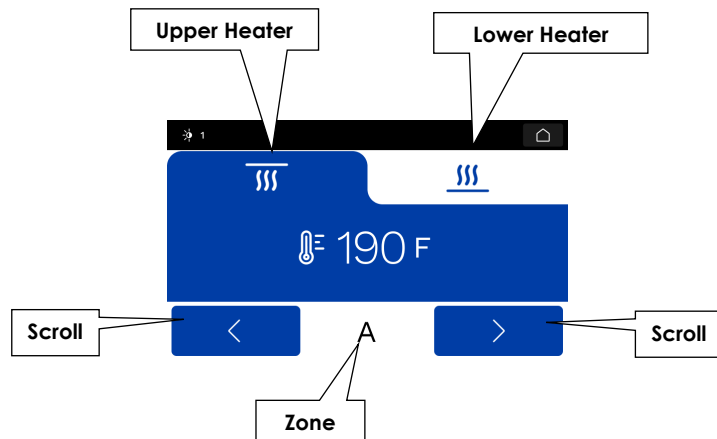

# HEATER CALIBRATION

**4** Adjust the program's temperature to reflect the heater surface temperature measured with a calibrated probe. When a value is changed, touch the checkmark to confirm and return to the Unit Settings screen.

*NOTE: To return without changing, touch the BACK icon.*

Repeat step 2 thru 4 for the other heater plates

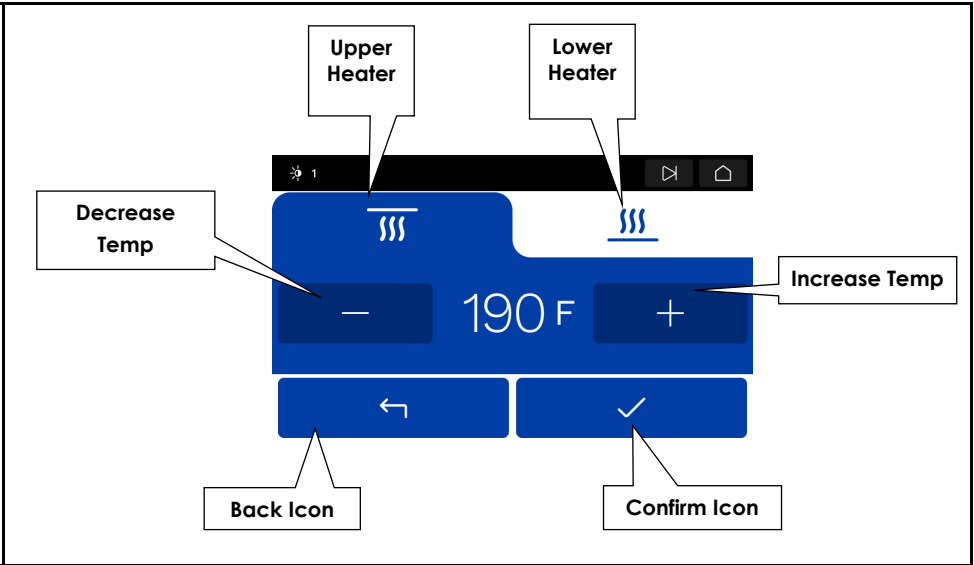

# CLEANING

 **CAUTION**

This equipment is not waterproof. Avoid cleaning it with a water jet or spray. Refrain from immersing the unit in water

**1** Put power switch in the OFF position. Power switches are located to the right of the touchscreen.

**2** Let unit cool down for up to 30 minutes, OR complete the task first thing in the morning BEFORE turning on the unit. Put power switch in the OFF position. Power switches are located to the right of the touchscreen.

 **CAUTION**

Before unplugging the power cord, make sure the power switches are in the OFF position.

**3** Unplug the power cord from the outlet.

 **CAUTION**

Do **NOT** use any abrasive cleaners, pads, unapproved cleaners

**4** Wipe down surfaces with a damp cloth only

**5** Plug unit into outlet.

**6** Turn power on after all surfaces are dry.

# PARTS EXPLODED VIEW

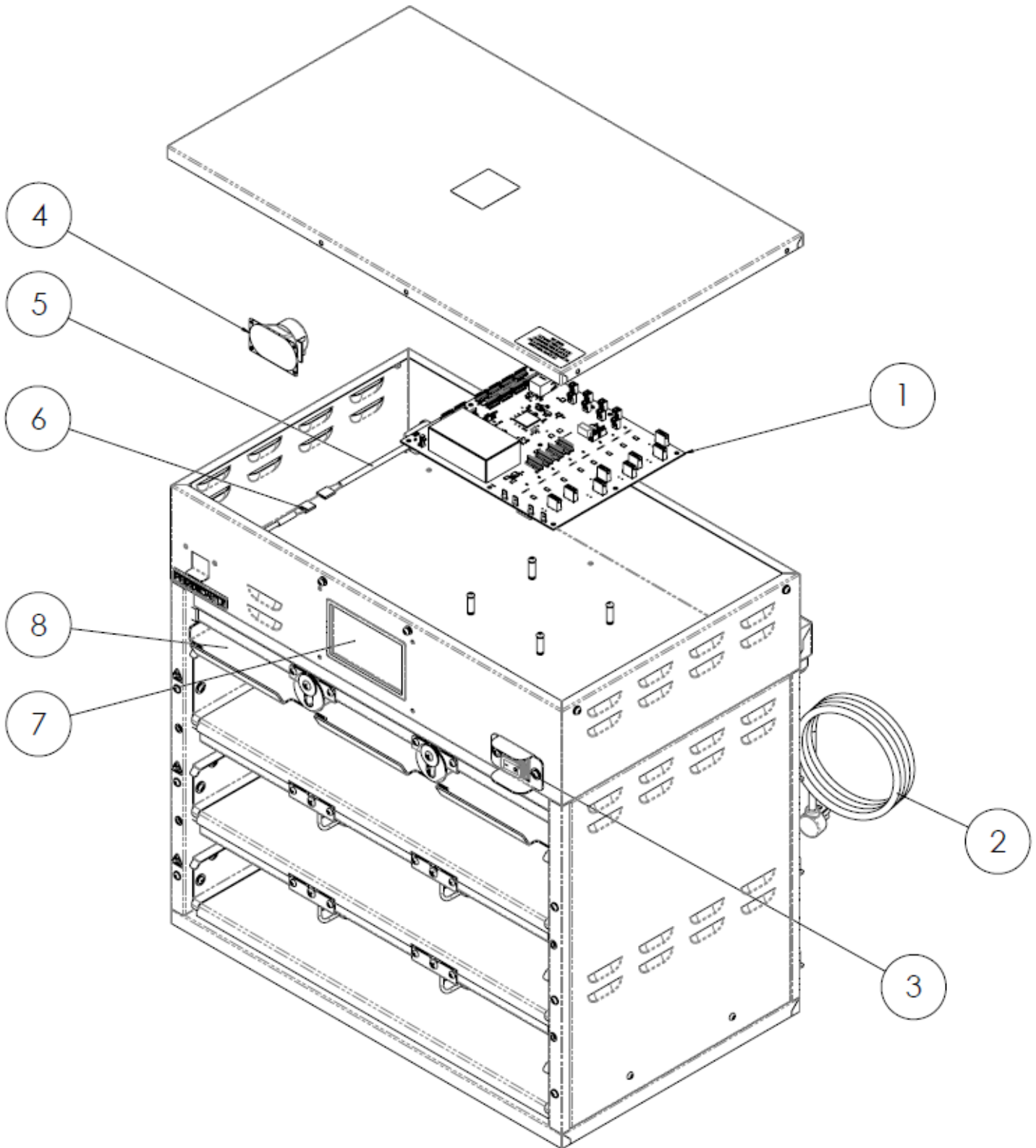

# PARTS EXPLODED VIEW

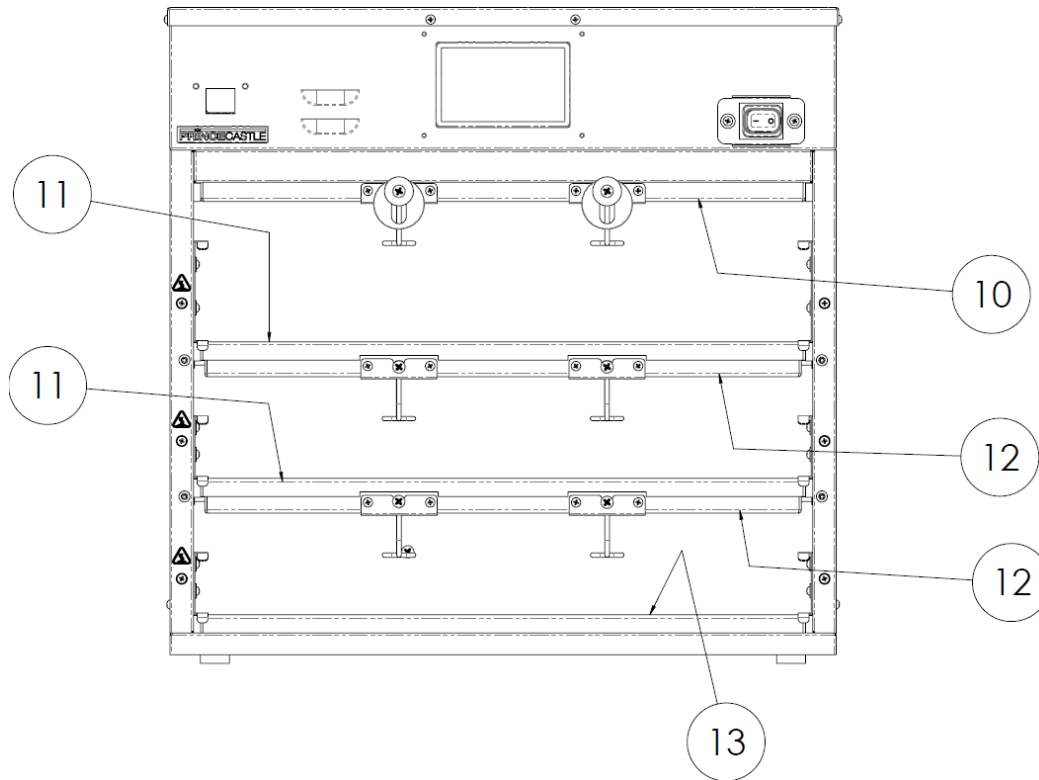

# PARTS LIST

ITEM #	PART #	DESCRIPTION
1	545-169S	KIT, PCB MAIN
2	72-807S	POWER CORD 120V 20A 5-20P
3	78-184S	POWER SWITCH
4	88-709-2-11S	SPEAKER ASSY
5	95-2011S	ETHERNET CABLE
6	95-1819S	USB CORD
7	1265-001S	KIT, LCD DISPLAY
8	540-1251	LID (QTY 1)
10	545-159S	TOP HEATER ASSEMBLY
11	545-157S	UPPER HEATER ASSEMBLY
12	545-158S	LOWER HEATER ASSEMBLY
13	545-156S	BOTTOM HEATER ASSEMBLY
NA	301-092S	LCD DISPLAY RIBBON CABLE
	541-1095S-1S	1/3 2.5" SINGLE HANDLE PAN (QTY 1)
	541-442S	1/3 2.5" DUAL HANDLE PAN (QTY 1)
	86-309	1/3 4.0" SINGLE HANDLE PAN (QTY 1)
	541-1406	1/3 4.0" DUAL HANDLE PAN (QTY 1)
	542-473S	KIT TRIVET 1/3 SIZE METAL (PKG OF 4)

# TROUBLESHOOTING

 **WARNING**

To avoid possible personal injury and/or damage to the unit, inspection, test and repair of electrical equipment should be performed by qualified service personnel. The unit should be unplugged when servicing, except when electrical tests are required. Use extreme care during electrical circuit tests. Live circuits will be exposed.



 **WARNING**

**BURN/ELECTRICAL SHOCK HAZARD!** Bins are HOT and can cause severe burns or severe shock. Keep hands and objects out of the unit! Failure to exercise caution may result in serious injury!

Let the unit cool down completely, turn it off and unplug it before touching or working on internal apparatus. The plug removed from the outlet shall remain clearly visible to the operator during the maintenance procedure.

For technical support or service, contact the MarmonLink Customer Care team @ **1-866-275-6392**

PROBLEM	POSSIBLE CAUSE	SOLUTION
Unit has no power	Unit unplugged.	Plug unit in.
	Breaker tripped.	Check / Reset breaker.
	Loose connection on power switch.	Call MarmonLink Customer Care team @ 1-866-275-6392
	Inoperable power switch.	
Heater measured temperature is more than 10F above OR below set point temperature	Heaters out of calibration	Perform heater calibration (see page 15)
E01 thru E40 code visible on display Sensor XX Error: Sensor is in either short or open condition. XX = 1 to 4 or 8 Heater Sensors	Open thermocouple circuit	Check thermocouple wires for continuity, an open circuit requires heater replacement
	Loose connection	Check connections at main PCB
E41 thru E80 code visible on display Heater XX Error: Heater is not heating up according to temp feedback. XX = 1 to 4 or 8 Heaters	Bad Heater	Check power to heater
		Check heater resistance (45.0 to 50.0 ohms when heaters are at room temperature)  Replace Heater
E81 code visible on display	Non-Volatile Memory Error.	Replace PCB (be sure to calibrate heaters <b>AFTER</b> PCB replacement)
E82 code visible on display	EEPROM Data Corrupt Error: CRC mismatch.	Replace PCB (be sure to calibrate heaters <b>AFTER</b> PCB replacement)
E83 code visible on display	USB File Upload Error: File operation error or CRC mismatch of file contents.	Make sure that there is only 1 file in the USB with one of the supported file extensions (*.bin, *.tun, *.mnu). Also make sure that the files on the root of the USB drive (not within a folder). Do not turn off the unit while the USB operation is in progress  USB thumb drive must be 4GB or less
E85 code visible on display	Menu/Tunable Error: Corruption of stored menu file and tunable.	Check if the file was generated correctly from the PC App tool.
Cleaning Notification visible on display	This indicates cleaning is required. It appears every 8 hrs.	Clean unit (see <i>Cool Down</i> and <i>Cleaning</i> sections).
Upgrade Successful Notification visible on display	This appears after USB upgrade.	Delete notification (see <i>Viewing and Adjusting Settings</i> section).

# WIRING DIAGRAM

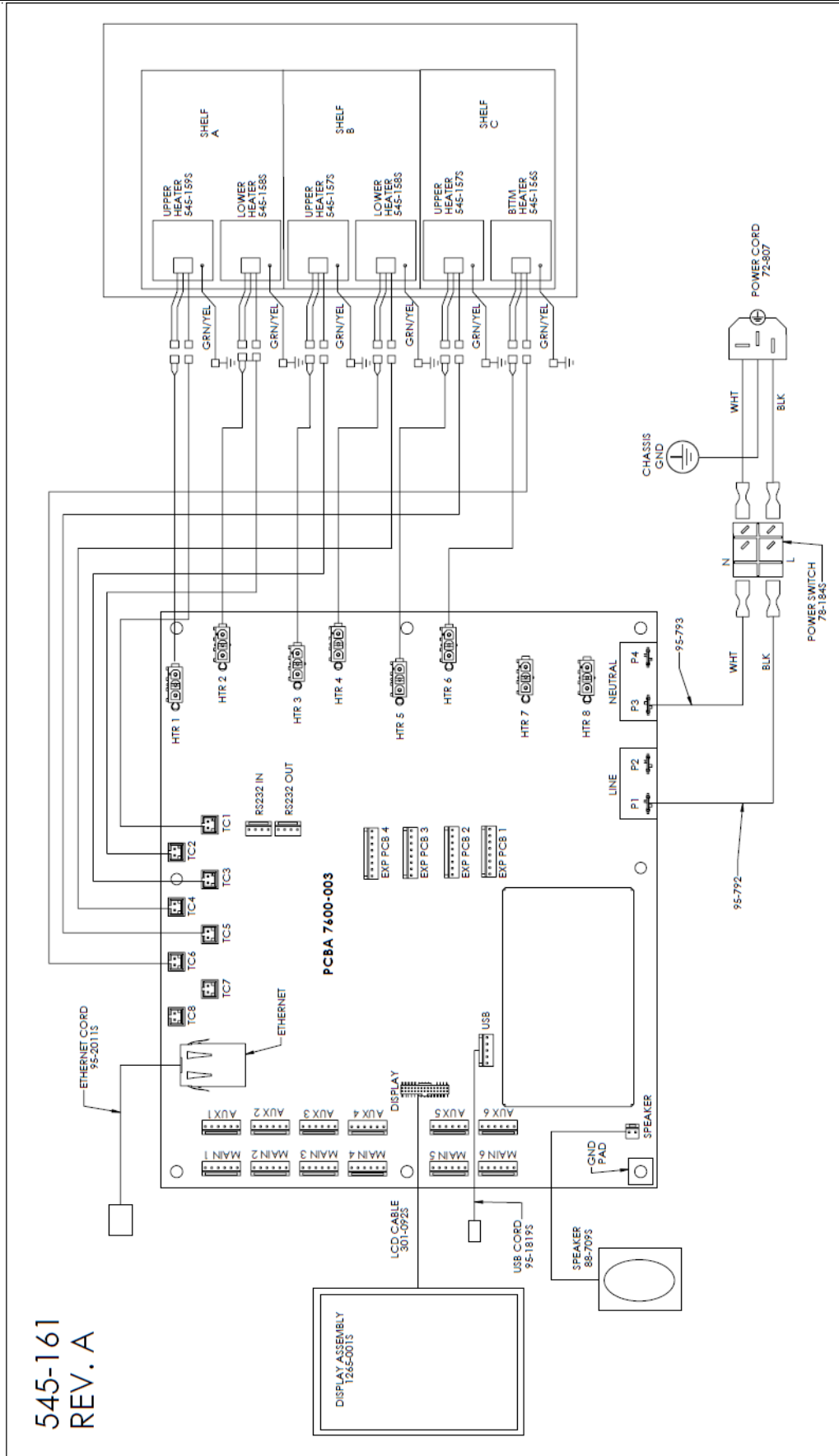

545-161  
REV. A