



# HP19-26 Heater Panels Product # HP19-26

Prince Castle's HP19-26 heater panels use infrared heaters that hold fried foods longer, have a better appearance, and are in better condition than foods held with cal rod heaters or heat lamps.

Work with your dealer / fabricator to determine what size heater panel you need and the best way to install.

**Required Accessory:** HPC-2 Heater Panel Controller

## Product Features

- Create heat that holds fried foods longer and better than calrods and heat lamps.
- Minimizes the heat bleeding out of the heated area, thus providing a more comfortable work environment for your employees.
- Installs easily into stainless steel fabrication.
- Can be retrofitted into most existing fabrication that utilizes calrods or heat lamps.
- The use of the HPC-2 controller allows the heater panels to cycle on and off thus increasing energy efficiency.

## Dimensions

Model Number	Length in (cm)	Depth in (cm)	Height in (cm)	Shipping Weight lbs (kg)
HP19-26	18.27 (46.4)	25.74 (65.4)	3.49 (8.9)	2.00 (.90)

## Electrical Information

Model Number	Volts	Hz	Watts	Amps
HP19-26	208-240	50/60	1290	6.2

## Specifications

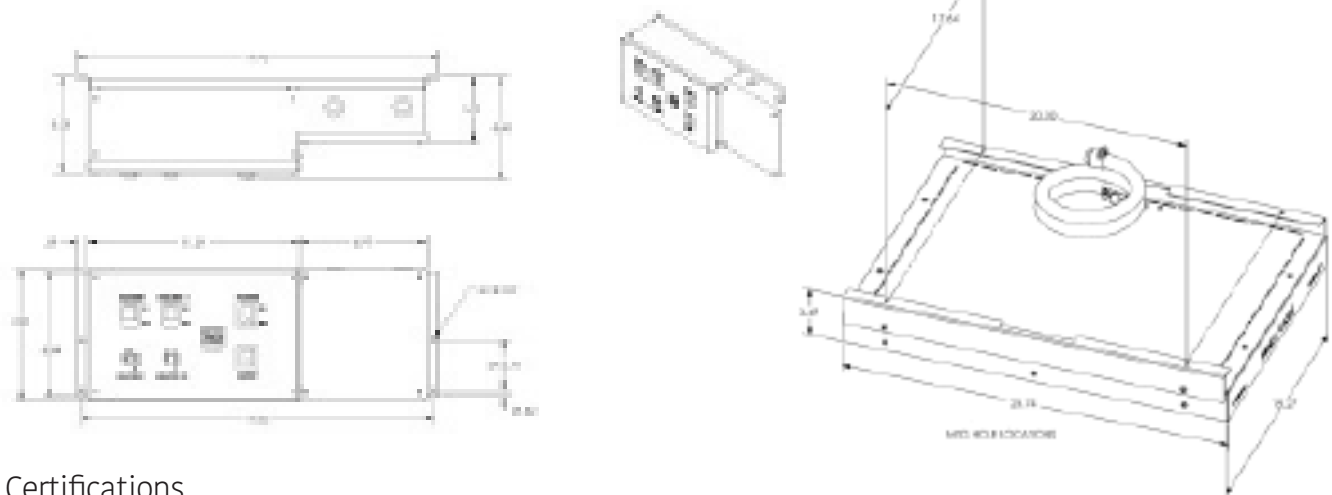

## Certifications



A Marmon / Berkshire Hathaway Company

© 2018 Prince Castle LLC - Specifications and design are subject to change without notice 03/2018



355 E. Kehoe Blvd.  
Carol Stream, IL 60188

1.800.PCASTLE • 630.462.8800  
www.princecastle.com