



DHB2PT-20B

FEATURES

- Independent upper and lower heating system per cavity.
- Adjustable temperature for each heater zone: Top and Bottom heater range: 150° to 260°F (65° to 127°C).
- Prince Castle pan indexing system designed to prevent incorrect pan placement and ensure precise holding temperatures and correct ambient conditions.
- Solid state digital controls.
- Equipped with MenuTrack food supervisory system.
- On/Off main power switch.
- Hold both fried and non-fried menu items in the same bin.
- Pass thru design allows employees to access the food from both sides.
- Unique pan lid system allows for perfect holding of moisture-sensitive foods, including hamburgers, grilled chicken and more.

MENUTRAK FEATURES:

- Identifies product and tracks holding times.
- Alphanumeric displays for each pan.
- Program up to six different menus.
- Easy to transfer products within existing or other DHBs.

**DHB2PT-20B
 DEDICATED HOLDING BIN**

The Prince Castle Dedicated Holding Bins (DHBs) provide the “work-in-process” capacity required for large foodservice operations while performing at peak energy efficiency. With stainless steel constructed exterior and cavity walls, the DHBs feature a solid state digital control system for precise heater temperature control.

The unit features two cavities, each accommodating two (2) third-size, 2 1/2” deep pans - holding a total of four pans. Adjustable upper and lower heaters offer maximum flexibility in setting the precise food holding temperatures.

Exclusive Reli-A-Temp® infrared heater technology holds food temperatures more consistent within the designated holding time than other types of heating systems. This exclusive heater design spreads the heat evenly over the entire food holding area, eliminating edge drop off. Food is kept at the desired serving temperature and not overcooked. Extended hold times reduce waste and offer the flexibility to address peak/off-peak demands.

With MenuTrak, Prince Castle DHBs “supervise” menu items by identifying where menu items are located and tracking their respective hold times. MenuTrak also indicates when you would discard old product and begin cooking new product, reassuring you that your customers are always being served your best.

The Prince Castle DHB is backed by a two-years parts and one-year on-site labor warranty.

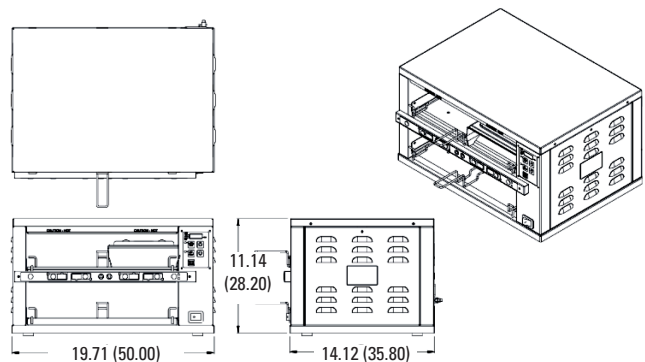

DIMENSIONS

Model Number	Width A in(cm)	Height B in(cm)	Depth C in(cm)	Shipping Weight lb(kg)
DHB2PT-20B	19.71 (50.00)	11.14	14.12 (35.80)	53.00 (24.00)

ELECTRICAL INFORMATION

Model Number	Description	Volts	Hz	Watts	Amps	Plug Number
DHB2PT-20B	2-shelf, 4-pan	120	60	2400 Max	10max	NEMA 5-20P

CERTIFICATIONS



ACCESSORIES

Model Number	Description
155695N-12	Replacement 1/3 Size Dual Handle Pans (Set of 12)
541-723E4S	Replacement 1/3 Size Can Covers (Set of 4)

Designs and Specifications are subject to change without notice.